

1D Laser Barcode Reader



The XtremeScan Grip XG930 laser 1D barcode scanner is a modular, rugged, handheld mobile device that combines an iPhone case, scanner, and pistol grip handle into an easy “point & shoot” industrial-grade solution. It has a long-range scanning capability, making it ideal for applications scanning barcodes on floor labels, and rack labels on high shelves. The integration of the scanner with a heavy-duty case is designed to withstand demanding industrial environments, and the pistol grip handle provides an extra level of comfort and convenience for constant scanning during long shifts. The XtremeScan case provides IP67 sealed housing and protects against jets of low-pressure water. It also uses inductive charging to charge the iPhone.

With a compatible iPhone, the XtremeScan Grip XG930 laser barcode scanner becomes a versatile and powerful mobile solution that can be used with a variety of industrial applications. The XG930 has a class 2 laser that scans through plastic or glass, in bright or poor lighting conditions, sideways, upside down, or straight at imperfect barcodes. Depending on the barcode symbology, width, size, and label media, the XS930 can scan from 1.2 inches (3.0 cm) to 180 inches (457.2 cm). The industrial-grade, rugged housing can handle multiple drops onto concrete.

FEATURES

- **Compatible with iPhone 15, 14 & 14 Pro, iPhone 13 & 13 Pro and iPhone 12 & 12 Pro.**
- **Scanning** – High-Performance 1D Class 2 laser, ideal for moderate to rigorous scanning applications (scans thousands of barcodes per day), scans up to 180” (457.2 cm) away with laser scanner. (Scan distance depends on size and quality of barcode).
- **Bluetooth Wireless Technology** – Dependable Bluetooth connection to iOS devices.
- **Long Lasting Replaceable Scanner Battery** - Power to last over 9 hours.
- **User Indicators** – Intuitive LED lights that indicate scanning and battery charging status.
- **Scanner Feedback** – Scanner provides audible scan tones to indicate successful scans.
- **Rugged Modular Design** – IP67 sealed housing for protection from dust and splashes of water; withstands multiple drops. The modular design provides future proofing, allowing for devices to be upgraded or changed to another supported mobile device. (Coming soon – device update kit to adapt XS930 to another supported mobile device, protecting your investment and ensuring your ability to upgrade to the latest technology).
- **Pistol Grip Handle** - Offers an alternative configuration for comfortable point & shoot barcode reading.
- **Protective** - Over molded rubber case protects both the Apple device and Socket Mobile scanner.
- **Charging** – Case charges both devices (iPhone & scanner).
- **Accessories** – Hand strap and charging dock coming soon (sold separately).
- **Application Integration** – Socket Mobile’s Capture SDK enables easy integration in your applications to improve business productivity with fast, efficient, and reliable data transfer over Bluetooth wireless technology. XG930 works out of the box for apps that have already integrated CaptureSDK.
- **Designed and Assembled in the USA.**
- **1- Year Warranty (Extended warranty options available).**

Physical Characteristics

Gewicht:

TBD



Single Package Includes

- (1) XG930 Laser Barcode Scanner and Rechargeable Battery (pre-installed)
- (1) Charging Cable
- (1) Get Started insert



Socket Mobile
Companion App
Gratis-Download!



Scanner Type

Technology:	1D Class 2 Laser Barcode Scanner
Laser Power at 650 nm :	Scanning Mode: 1.7 mW (nominal peak power) Aiming Mode: 0.67 mW

Battery

Type of Battery:	Replaceable Lithium Ion Polymer- rechargeable battery	
Charge Time:	8 Hours	
Battery Life - Per Full Charge:	Standby time:	25 hours
	Active Scan Time -	45,000 scans within 4.5 hours (based on 2 scans every 1 second) 9,000 scans within 10 hours (based on 1 scan every 4 seconds)
Note:	Battery life varies depending on ambient temperature, ambient light and age of battery. <i>For more battery information click here.</i>	
Number of Batteries Used:	1	
Weight of battery:	12.5g	
Percentage Lithium:	36%	
Battery mAh:	700 mAh	
Number of cells per battery:	1	
Watt Hours per battery:	2.59	
Type of Cell (ex. AA):	Proprietary	
Chemical Composition (ex. Alkaline):	Lithium - polymer	
Lithium Content:	14g	
Battery Voltage:	3.7v	
Hazmat UN Number:	UN3481, P.I. 967	
ROHS Compliance Indicator:	Yes, Included with Reader	
Battery only - Country of Origin:	China	
Commodity Code:	8507.60.0000	

Scanning Performance

Default Barcode Symbologies:

Bookland EAN, Code 39, Code 39 Full ASCII, Code 93, Code 128, EAN-8/JAN, Ean-13/JAN, GS1 DataBar, GS1 Databar Expanded, GS1 DataBar Limited, GS1-128, Interleaved 2 of 5, ISBT 128, UPC A, UPC E

Supported Barcode Symbologies:

Bookland EAN, Chinese 2 of 5, Codabar, Code 11, Code 39, Code 93, Code 128, Discrete 2 of 5, EAN-8, EAN 13, GS1-128, GS1 Databar, GS1 Databar Expanded, GS1 Databar Limited, Interleaved 2 of 5, Inverse 1D, ISBT 128, Korean 3 of 5, Matrix 2 Of 5, MSI, UPC-A, UPC-E/ E1

Scan Angle:

Wide: 47° (Default) Medium: 35° Narrow: 10°

Optical Resolution:

0.005 in. Minimum element width

Print Contrast:

Minimum 25% absolute dark/light Reflectance measured at 650 nm

Reading Distance:

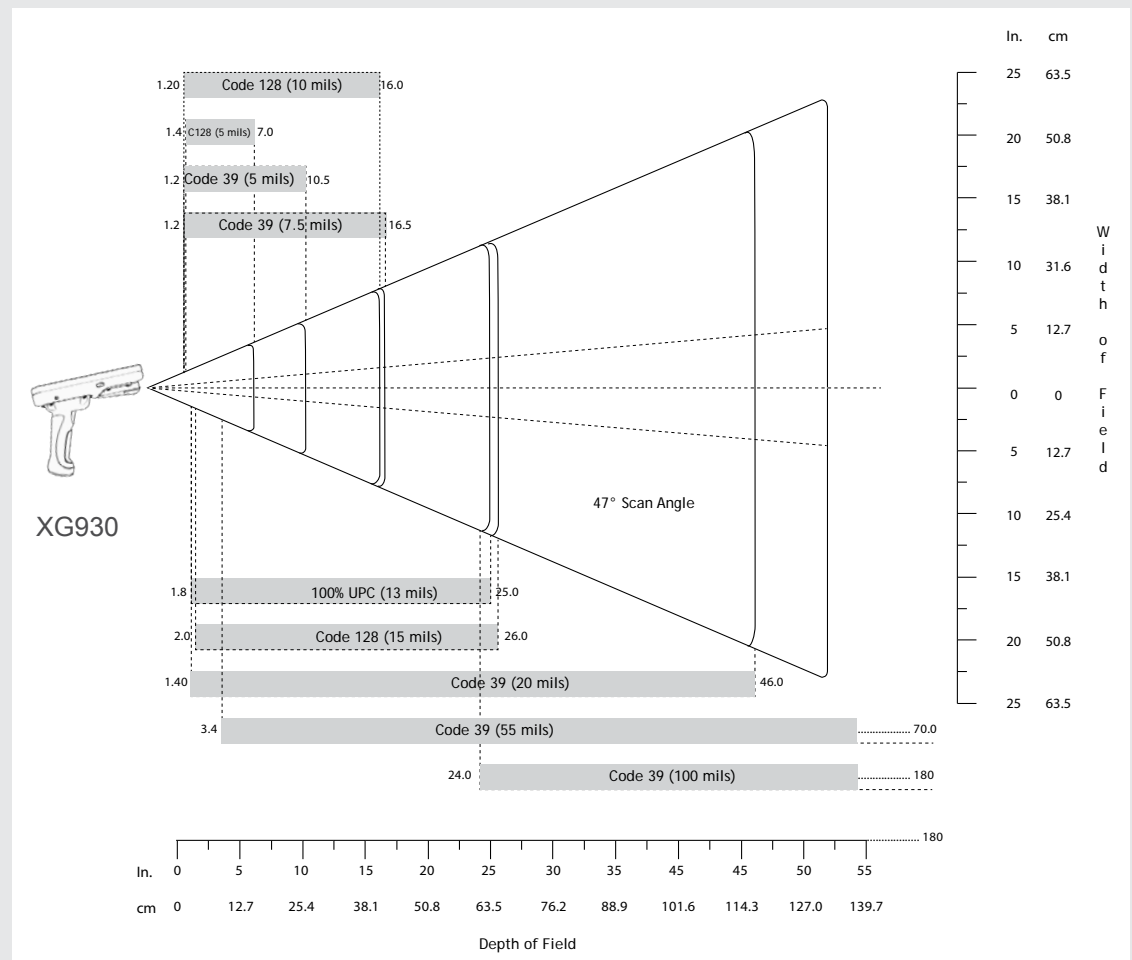

1D codes 3.05 to 457.2 cm (1.2 in to 180 in)

Depends on width and barcode size, symbology, label media

Decode Ranges:

	Near	Far
5 mils Code 39	1.2 in/3.0 cm	10.5 in/21.0 cm
5 mils Code 128	1.4 in/3.6 cm	7.0 in/26.7 cm
7.5 mils Code 39	1.2 in/3.0 cm	16.5 in/41.9 cm
10 mils Code 128	1.2 in/3.0 cm	16.0 in/40.6 cm
13 mils 100% UPC	1.8 in/4.6 cm	25.0 in/63.5 cm
15 mils Code 128	2.0 in/5.1 cm	26.0 in/66.0 cm
20 mils Code 39	1.4 in/3.6 cm	46.0 in/116.8 cm
55 mils Code 39	3.4 in/8.6 cm	70.0 in/177.8 cm
100 mils Code 39	24 in/61 cm	180.0 in/457.2 cm

Bluetooth (wireless connection)

Bluetooth Radio:	Class 2 Bluetooth, version 2.1 + EDR (Enhanced Data Rates) with 56-bit data encryption
Bluetooth Range:	Up to 10 meters (33 ft.) depending on environment, range limit is usually due to the Host Device (phone, tablet or notebook)
Bluetooth Profiles:	Basic Mode - Human Interface Device (HID) and App Mode - MFi-SPP*. Some Operating Systems or smartphone/tablet models may support only one profile. <i>*By default, the scanner is set to App Mode - MFi-SPP.</i>

Apple, Android and Windows PC with Bluetooth Classic HID are compatible with all Socket Mobile scanners.

*Chromebook and Linux support HID mode only.

User Environment

Ambient Light:	From 4,800 to 86,000 lux From artificial indoor (fluorescent and incandescent) to natural outdoor lighting (direct sunlight)
Operating Temperature:	0° to 45° C (32° to 113° F)
Storage Temperature:	-5° to 70° C (-22° to 158° F)
Charging Temperature:	Charging in an ambient temperature above 40° C / 100° F may result in charging issues.
Relative Humidity:	95% at 60° C (140° F) (non-condensing)
Sealing:	IP65 (Ingress protection rating for dust and water) meets IEC sealing and EN60529 specification
Drop Specification:	Standard: 10 ft. (3.1m) drop at room temperature per MIL-STD-810G, 8 ft. (2.4m) drop to concrete across temperature per MIL-STD-810G Freezer: 7 ft. (2.1m) drop to concrete across temperature per MIL-STD-810G.

Operating System Compatibility

Apple iOS - Basic Mode (HID) and App Mode (MFi-SPP)*

Compatible with devices supporting Basic Mode (HID) protocol. Supported keyboard languages - ANSI, English UK, English, French, German, Italian, Japanese, Polish, Spanish and Swedish

**By default, the factory settings of the Socket Mobile Scanners are set to App Mode. In order to use the scanner with an application using Capture SDK, the scanner must be configured in Application Mode (Bluetooth Serial Port Profile: SPP)*

Warranty

Scanner:	Standard one year limited warranty for barcode scanners
Accessories:	90 days for batteries, charging cable
Extended Warranty: (sold separately)	https://sckt.tech/socketcare



Certification & Regulatory

Bluetooth SIG:	Declaration ID: D030529 QD ID: 82009
Electrical Safety:	EN 62368-1:2020 + A11:2020 IEC 62368-1:2018 UL 62368-1:2019 R10.21 CSA C22.2 NO. 62368-1:19
Environmental:	Environmental: RoHS EN 50581
EMI / RFI:	FCC Part 15 Class C, RSS 210, iCES 003, C-Tick, CISPR 22, CE EN55022, EN55024, TELECOM: FCC ID: LUBMA41 IC ID: 2529A-MA41M9
LED Safety:	IEC 60825-1, EN 60825-1



Common Uses

- Warehouse Inventory management
- Supply Chain Management
- Asset Tracking
- Shipping and Receiving
- Commercial Services Mobile Tracking
- Industrial & Manufacturing
- Construction
- Automotive
- Oil and gas
- Aerospace
- Transportation & Logistics

socketmobile.com

Worldwide: +1 510 933 3000
North America: +1 800 552 3300
EMEA: +41 62 834 07 80
France: +33 970 462 241

sales@socketmobile.com

Asia Pacific: +1 510 933 3122
Germany: +41 62 834 07 80
Switzerland: +41 62 834 07 80
Switzerland Toll-Free: +41 (800) 898003

sales-japan@socketmobile.com

Japan: +8190 9808 0518
Japan Toll-Free: +81 (800) 9190303
Latin America: +1-510-933-3153
UK/Ireland/South Africa: +44 (800) 0487363

©2024 Socket Mobile, Inc. All rights reserved. Socket®, the Socket Mobile logo, DuraScan®, SocketScan®, Battery Friendly® are registered trademarks or trademarks of Socket Mobile, Inc. Microsoft® is a registered trademark of Microsoft Corporation in the United States and other countries. Apple®, iPad®, iPad Mini®, iPhone®, iPod Touch®, and Mac iOS® are registered trademarks of Apple, Inc., registered in the U.S. and other countries. The Bluetooth® Technology word mark and logos are registered trademarks owned by the Bluetooth SIG, Inc. and any use of such marks by Socket Mobile, Inc. is under license. Other trademarks and trade names are those of their respective owners.

1D-Laser-Barcode-Scanner



Der XtremeScan Grip XG930, ein 1D-Laser-Barcode-Scanner, ist ein modulares, robustes und mobiles Handgerät, das eine iPhone-Hülle, einen Scanner und einen Pistolengriff zu einer einfachen „Point & Shoot“-Lösung in Industriequalität kombiniert. Mit seiner großen Scan-Reichweite ist er ideal für Anwendungen, bei denen Barcodes auf Bodenaufklebern und Regaletiketten in großen Höhen gescannt werden. Der XG930 wurde in eine strapazierfähige Hülle integriert, dadurch ist er speziell für den Einsatz in anspruchsvollen Industrieumgebungen ausgelegt. Der Pistolengriff sorgt zusätzlich für Komfort und Bequemlichkeit in langen Arbeitsschichten. Die Hülle ist nach IP67 abgedichtet, sie schützt auch vor Niederdruckwasserstrahlen. Außerdem verfügt der XG930 über ein integriertes kabelloses Ladegerät, mit dem das iPhone aufgeladen werden kann, ohne es extra aus der Hülle zu nehmen.

In Kombination mit einem kompatiblen iPhone wird der Laser-Barcode-Scanner zu einer vielseitigen und leistungsstarken Mobil-Lösung, die für eine Vielzahl industrieller Anwendungen eingesetzt werden kann. Das Gerät verfügt über einen Laser der Klasse 2, liest durch Plastik oder Glas, ebenso in gleißendem Licht oder bei schlechten Lichtverhältnissen. Mit dem XG930 können Sie seitwärts, von oben nach unten oder geradeaus und auf fehlerhafte Barcodes zielen. Abhängig von Barcode-Symbologie, Breite, Größe und Etikettenmedium kann der XG930 zwischen 3 cm und 457,2 cm eingesetzt werden. Das robuste, industrietaugliche Gehäuse kann mehrere Stürze auf Beton überstehen.

LEISTUNGSMERKMALE

- **Kompatibel mit iPhone 14 & 14 Pro, iPhone 13 & 13 Pro und iPhone 12 & 12 Pro.**
- **Scannen** – Leistungsstarker 1D-Laser-Scanner der Klasse 2, ideal für moderate und anspruchsvolle Scan-Anwendungen (tausende von Barcodes pro Tag), liest aus bis zu 457,2 cm Entfernung. (Der reale Scan-Abstand hängt von Größe und Qualität des Barcodes ab).
- **Bluetooth-Drahtlostechnologie** – Zuverlässige Bluetooth-Verbindung zu iOS-Geräten.
- **Battery Friendly[®]** – Der Barcode-Scanner verfügt über einen vor Ort austauschbaren Akku mit Energie für eine ganze Arbeitsschicht.
- **Anwenderanzeigen** – Intuitive LED-Lichter zeigen Scan- und Akkuladestatus des Scanners an.
- **Scanner-Feedback** – Scanner zeigt erfolgreiche Scans durch akustische Signale an.
- **Robustes Design** – IP65-versiegeltes Gehäuse zum Schutz vor Staub und Spritzwasser; übersteht mehrere Stürze.
- **Pistolengriff** – Alternative Konfiguration für bequemes Lesen von Barcodes im Point & Shoot-Verfahren.
- **Schutzwerkstoff** – Die übergeformte, gut sitzende, gummierte Hülle schützt sowohl das Apple-Gerät als auch den Socket-Mobile-Scanner.
- **Aufladen** – Die Hülle lädt beide Geräte (Apple-iPhone und Socket-Mobile-Scanner).
- **Zubehör** – Handschlaufe und Tischladegerät demnächst erhältlich (separat oder als festes Zubehörteil).
- **Anwendungsintegration** – Das Socket Mobile Capture SDK ermöglicht die einfache Integration Ihrer Anwendungen, um Ihre Unternehmensproduktivität durch schnelle, effiziente und verlässliche Datenübertragung mithilfe drahtloser Bluetooth-Technologie zu verbessern. Der XG930 ist sofort einsetzbar für Anwendungen, die CaptureSDK bereits integriert haben.
- **Designed und hergestellt in den USA.**
- **1 Jahr Garantie (Optionale Garantieverlängerungen erhältlich).**

Physische Merkmale

Gewicht:

TBD

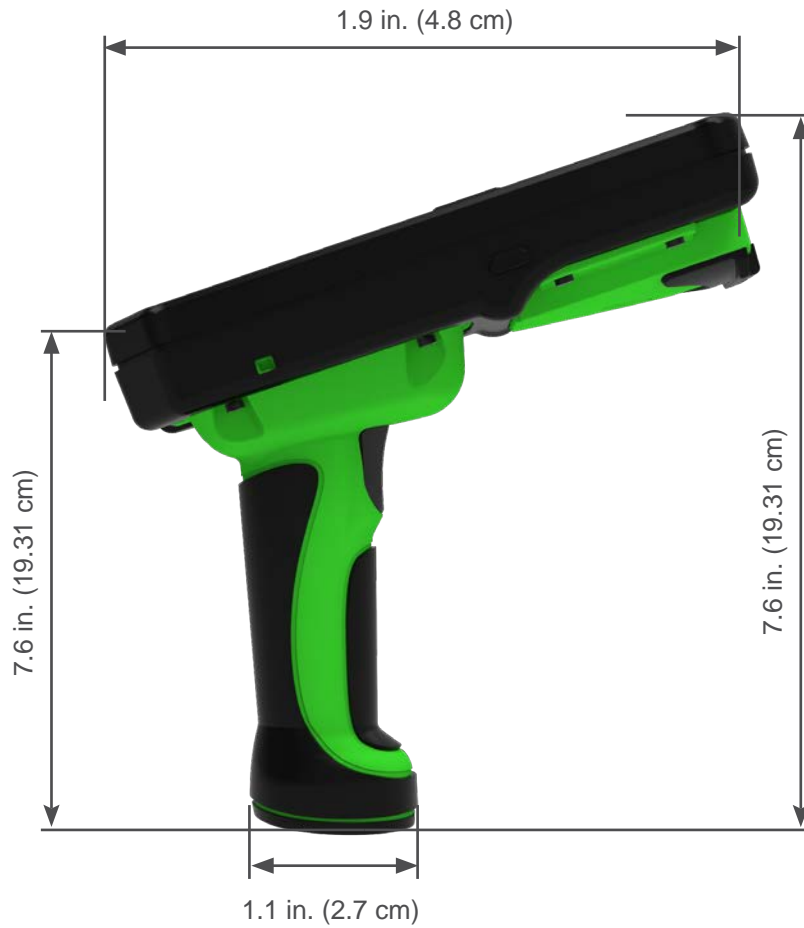

Lieferumfang (Einzelpackung)

- (1) XG930 Laser-Barcode-Scanner und Akku (vorinstalliert)
- (1) Ladekabel
- (1) Schnellstartanleitung



Socket Mobile
Companion App
Gratis-Download!



Scannertyp

Technologie:	1D-Laser-Barcode-Scanner der Klasse 2
Laserleistung bei 650 nm:	Scan-Modus: 1,7 mW (Nominale Spitzenleistung) Anvisier-Modus: 0,67 mW

Akku

Akkutyp:	Replaceable Lithium Ion Polymer- rechargeable battery	
Ladezeit:	8 Hours	
Akkulaufzeit – Bei voller Ladung:	Standby time:	25 hours
	Active Scan Time -	45,000 scans within 4.5 hours (based on 2 scans every 1 second) 9,000 scans within 10 hours (based on 1 scan every 4 seconds)
Hinweis:	<i>Die Akkuleistung ist abhängig von Umgebungstemperatur, Umgebungslicht und Akkualter. Für weitere Informationen zum Thema Akkus klicken Sie bitte hier.</i>	
Anzahl verwendeter Akkus:	1	
Akkugewicht:	12,5g	
Prozentualer Lithiumanteil:	36%	
Akku-mAh:	700 mAh	
Anzahl Zellen pro Akku:	1	
Wattstunden pro Akku:	2,59	
Zelltyp (z. B. AA):	Proprietär	
Chemische Zusammensetzung (z. B. alkalisch):	Lithium - polymer	
Lithiumgehalt:	14g	
Akkuspannung:	3,7v	
Gefahrgut-UN-Nummer:	UN3481, P.I. 967	
ROHS-Konformitätsanzeige:	Ja, im Lieferumfang des Lesegeräts enthalten	
Herkunftsland des Akkus (COO):	China	
Warennummer:	8507.60.0000	

Scanleistung

Standard-Barcode-Symbologien:

Bookland EAN, Code 39, Code 39 Full ASCII, Code 93, Code 128, EAN-8/JAN, Ean-13/JAN, GS1 DataBar, GS1 Databar Expanded, GS1 DataBar Limited, GS1-128, Interleaved 2 of 5, ISBT 128, UPC A, UPC E

Unterstützte Barcode-Symbologien:

Bookland EAN, Chinese 2 of 5, Codabar, Code 11, Code 39, Code 93, Code 128, Discrete 2 of 5, EAN-8, EAN 13, GS1-128, GS1 Databar, GS1 Databar Expanded, GS1 Databar Limited, Interleaved 2 of 5, Inverse 1D, ISBT 128, Korean 3 of 5, Matrix 2 Of 5, MSI, UPC-A, UPC-E/ E1

Scanwinkel:

Wide: 47° (Default) Medium: 35° Narrow: 10°

Optische Auflösung:

0.005 in. Minimum element width

Druckkontrast:

Minimum 25% absolute dark/light Reflectance measured at 650 nm

Scanreichweite:

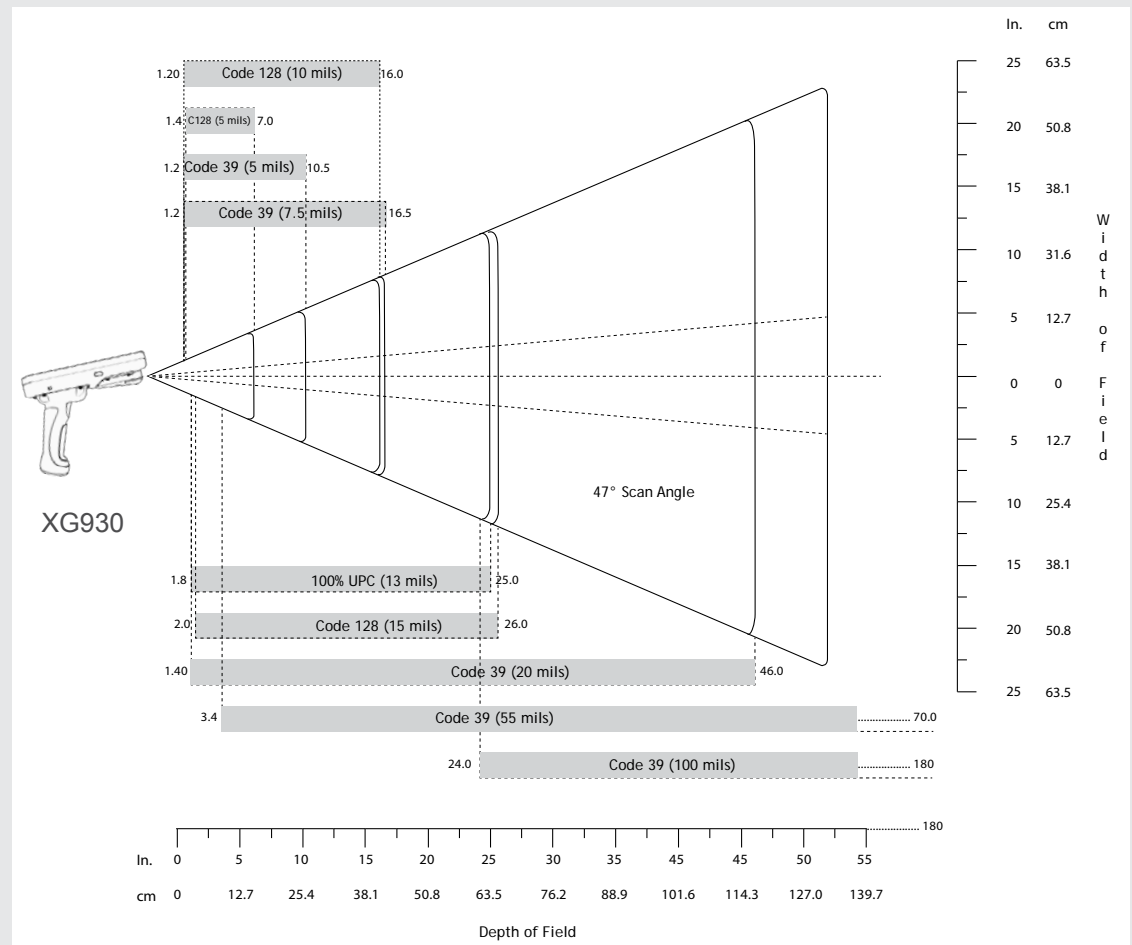

1D-Codes 3,05 bis 457,2 cm

Abhängig von Barcode-Breite & -Größe, Symbologie, Etikett

Dekodierreichweite:

	Near	Far
5 mils Code 39	1.2 in/3.0 cm	10.5 in/21.0 cm
5 mils Code 128	1.4 in/3.6 cm	7.0 in/26.7 cm
7.5 mils Code 39	1.2 in/3.0 cm	16.5 in/41.9 cm
10 mils Code 128	1.2 in/3.0 cm	16.0 in/40.6 cm
13 mils 100% UPC	1.8 in/4.6 cm	25.0 in/63.5 cm
15 mils Code 128	2.0 in/5.1 cm	26.0 in/66.0 cm
20 mils Code 39	1.4 in/3.6 cm	46.0 in/116.8 cm
55 mils Code 39	3.4 in/8.6 cm	70.0 in/177.8 cm
100 mils Code 39	24 in/61 cm	180.0 in/457.2 cm

Bluetooth (Drahtlosverbindung)

Bluetooth-Funkverbindung:	Klasse 2-Bluetooth, Version 2.1 + EDR (Enhanced Data Rates) mit 56-Bit Datenverschlüsselung
Bluetooth-Reichweite:	Bis zu 10 m, abhängig von der Umgebung, ebenso basiert die Reichweite üblicherweise auf dem verwendeten Endgerät (Smartphone, Tablet oder Notebook)
Bluetooth-Profile:	<i>Grundeinstellung – Human Interface Device (HID), Anwendungsmodus – Serial Port Profile (SPP) und Anwendungsmodus – MFi-SPP*. Einige Betriebssysteme oder Smartphone- bzw. Tablet-Modelle unterstützen ggf. nur eines der Profile. * Standardmäßig befindet sich der Scanner im Anwendungsmodus - MFi-SPP.</i>

Apple, Android und Windows-PCs mit Bluetooth Classic HID sind mit allen Socket-Mobile-Scannern kompatibel. * Chromebook und Linux unterstützen nur den HID-Modus.

Nutzerumgebung

Umgebungsbeleuchtung:	From 4,800 to 86,000 lux From artificial indoor (fluorecent and incandescent) to natural outdoor lighting (direct sunlight)
Arbeitstemperatur:	0° to 45° C (32° to 113° F)
Lagertemperatur:	-5° to 70° C (-22° to 158° F)
Ladetemperatur:	Charging in an ambient temperature above 40° C / 100° F may result in charging issues.
Relative Luftfeuchtigkeit:	95% at 60° C (140° F) (non-condensing)
Abdichtung:	IP65 (Schutzklasse gegen Eindringen von Staub und Wasser) entspricht der IEC-Abdichtung und der EN60529-Spezifikation
Sturzeigenschaften	Standard: Stürze aus 3,1 Meter, Raumtemperatur gemäß MIL-STD-810G, Stürze aus 2,4 Meter auf Beton, Raumtemperatur gemäß MIL-STD-810G. Tiefkühlbereich: Stürze aus 2,1 Meter auf Beton, Raumtemperatur gemäß MIL-STD-810G.

Betriebssystemkompatibilität

Apple iOS – Grundeinstellung (HID) & Anwendungsmodus (MFi-SPP)

Kompatibel mit Geräten, die das Grundeinstellungsprotokoll (HID)* unterstützen. Unterstützte Tastatursprachen – ANSI, Englisch (UK), Englisch, Französisch, Deutsch, Italienisch, Japanisch, Polnisch, Spanisch und Schwedisch

Garantie

Scanner:	1 Jahr eingeschränkte Standardgarantie auf Barcode-Scanner
Zubehör:	90 Tage auf Akku, Ladekabel
Garantierweiterung:(separat erhältlich)	https://sckt.tech/socketcare-de



Zertifizierungen & Regulierungen

Bluetooth SIG:	Declaration ID: D030529 QD ID: 82009
Elektrische Sicherheit:	EN 62368-1:2020 + A11:2020 IEC 62368-1:2018 UL 62368-1:2019 R10.21 CSA C22.2 NO. 62368-1:19
Umweltspezifikationen:	Environmental: RoHS EN 50581
EMI / RFI:	FCC Part 15 Class C, RSS 210, iCES 003, C-Tick, CISPR 22, CE EN55022, EN55024, TELEC: FCC ID: LUBMA41 IC ID: 2529A-MA41M9
LED-Sicherheit:	IEC 60825-1, EN 60825-1



Häufige Einsatzgebiete

Lagerverwaltung & Warenmangement

Lieferkettenmanagement

Asset Tracking (Nachverfolgung)

Warenversand & Warenempfang

Kommerzielle Dienstleistungen Mobiles Tracking

Industrie & Produktion

Bauwesen

Automobilindustrie

Öl und Erdgas

Luft- und Raumfahrt

Transport & Logistik

socketmobile.com

Worldwide: +1 510 933 3000

North America: +1 800 552 3300

EMEA: +41 62 834 07 80

France: +33 970 462 241

sales@socketmobile.com

Asia Pacific: +1 510 933 3122

Germany: +41 62 834 07 80

Switzerland: +41 62 834 07 80

Switzerland Toll-Free: +41 (800) 898003

sales-japan@socketmobile.com

Japan: +8190 9808 0518

Japan Toll-Free: +81 (800) 9190303

Latin America: +1-510-933-3153

UK/Ireland/South Africa: +44 (800) 0487363

©2024 Socket Mobile, Inc. All rights reserved. Socket®, the Socket Mobile logo, DuraScan®, SocketScan®, Battery Friendly® are registered trademarks or trademarks of Socket Mobile, Inc. Microsoft® is a registered trademark of Microsoft Corporation in the United States and other countries. Apple®, iPad®, iPad Mini®, iPhone®, iPod Touch®, and Mac iOS® are registered trademarks of Apple, Inc., registered in the U.S. and other countries. The Bluetooth® Technology word mark and logos are registered trademarks owned by the Bluetooth SIG, Inc. and any use of such marks by Socket Mobile, Inc. is under license. Other trademarks and trade names are those of their respective owners.

Escáner de códigos de barras láser 1D



El escáner de códigos de barras láser 1D XtremeScan Grip XG930 es un dispositivo móvil portátil y modular que combina una carcasa robusta para iPhone y un mango antideslizante en forma de pistola, lo que proporciona una solución de calidad industrial con un sencillo sistema de «apuntar y disparar». Gracias a su láser de gran alcance, es perfecto para escanear códigos de barras en etiquetas a nivel del suelo o en estanterías altas. La integración del escáner con una carcasa robusta ha sido diseñada para resistir en los entornos industriales. El mango en forma de pistola proporciona una comodidad de uso adicional, haciendo el escáner más práctico para los largos turnos en los que se escanea constantemente. La carcasa XtremeScan tiene un índice de estanqueidad IP65 y ofrece protección contra proyecciones de agua a baja presión. Incluye un cargador inalámbrico integrado, para que pueda cargar su iPhone sin sacarlo de la carcasa.

Combinado con un iPhone compatible, el escáner de códigos de barras láser XtremeScan Grip XG930 se convierte en una solución móvil versátil y potente que puede usarse en gran cantidad de aplicaciones industriales. El XG930 cuenta con un láser de clase 2 que consigue escanear a través de plástico o cristal, en entornos oscuros o con demasiada luz, apuntando de lado o al revés si los códigos son de buena calidad, o de frente si los códigos están dañados. Dependiendo de la simbología, el ancho y el tamaño del código de barras o del tipo de etiqueta, el XG930 puede escanear a una distancia que varía entre 3 y 457 cm. La carcasa de calidad industrial resiste a múltiples caídas a hormigón desde 2 m.

CARACTERÍSTICAS

- **Compatible con iPhone 14 y 14 Pro, iPhone 13 y 13 Pro y iPhone 12 y 12 Pro.**
- **Escaneo:** este lector 1D incorpora un láser de clase 2 de alto rendimiento que lo hace ideal para un uso de moderado a intensivo (lee miles de códigos de barras al día). Lectura eficaz hasta una distancia máxima de 457 cm. (La distancia de escaneo dependerá del tamaño y calidad del código de barras).
- **Tecnología inalámbrica Bluetooth:** conexión fiable por Bluetooth con dispositivos iOS.
- **Batería Battery Friendly®:** incluye una batería recargable que se cambia in situ y que dura una jornada de trabajo entera.
- **Indicadores:** dotado de indicadores LED intuitivos para señalar el estado del escaneo o el nivel de carga de batería.
- **Información para usuarios:** el escáner proporciona notificaciones sonoras cuando se completa con éxito el escaneo.
- **Diseño robusto:** carcasa con estanqueidad IP67 que protege de polvo y proyecciones de agua; resiste múltiples caídas.
- **Mango en forma de pistola:** configuración alternativa para escanear cómodamente, gracias a su sistema «apuntar y disparar».
- **Protección reforzada:** la carcasa de goma diseñada específicamente para este modelo protege su dispositivo Apple y el escáner.
- **Carga:** la carcasa carga ambos dispositivos (iPhone de Apple y escáner Socket Mobile).
- **Accesorios:** correa para muñeca y estación de carga disponibles próximamente (vendidas por separado o en paquete).
- **Integración de aplicaciones:** CaptureSDK de Socket Mobile permite una integración sencilla a sus aplicaciones y mejora la productividad de su empresa gracias a la transferencia rápida, eficaz y fiable de sus datos a través de la tecnología inalámbrica Bluetooth. XG930 funciona sin necesidad de instalación con las apps que hayan integrado CaptureSDK.
- **Diseñado y ensamblado en EE. UU.**
- **Garantía de 1 año (opciones de extensión de garantía disponibles).**

Características físicas

Peso:

TBD



El paquete incluye

- (1) Escáner de códigos de barras láser XG930 y Batería recargable (preinstalada)
- (1) Cable de carga
- (1) Ficha de inicio rápido



Socket Mobile
Companion App
Gratis-Download!



Tipo de escáner

Tecnología:	Batería recargable reemplazable: polímero de iones de litio
Potencia del láser a 650 nm:	Modo de lectura: 1,7 mW (potencia nominal máxima) Modo de enfoque: 0,67 mW

Batería

Tipo de batería:	Replaceable Lithium Ion Polymer- rechargeable battery	
Tiempo de carga:	8 horas	
Duración de la batería - por cada ciclo de carga completo:	Tiempo en reposo:	25 horas
	Tiempo de escaneo activo-	45.000 escaneos en 4,5 horas (basado en 2 escaneos por segundo) 9.000 escaneos en 10 horas (basado en 1 escaneo cada 4 segundos)
Aviso:	<i>La duración de la batería depende de la temperatura, la luz ambiente y la antigüedad de la batería. Para más información sobre la batería, consulte esta página.</i>	
Número de baterías:	1	
Peso de la batería:	12,5g	
Porcentaje de litio:	36%	
mAh de la batería:	700 mAh	
Celdas por batería:	1	
Vatios hora por batería:	2,59	
Tipo de celda (p. ej. AA):	Proprietario	
Composición química (p. ej. Alcalina):	Polímero de litio	
Contenido en litio:	14g	
Voltaje de la batería:	3,7v	
Número ONU de mercancías peligrosas:	UN3481, P.I. 967	
Indicador del cumplimiento de la directiva RoHS:	Sí, incluido con el lector	
País de origen de la batería:	China	
Código de mercancías:	8507.60.0000	

Rendimiento de escaneo

Simbologías de códigos de barras predeterminadas:

Bookland EAN, Code 39, Code 39 Full ASCII, Code 93, Code 128, EAN-8/JAN, Ean-13/JAN, GS1 DataBar, GS1 Databar Expanded, GS1 DataBar Limited, GS1-128, Interleaved 2 of 5, ISBT 128, UPC A, UPC E

Simbologías de códigos de barras soportadas:

Bookland EAN, Chinese 2 of 5, Codabar, Code 11, Code 39, Code 93, Code 128, Discrete 2 of 5, EAN-8, EAN 13, GS1-128, GS1 Databar, GS1 Databar Expanded, GS1 Databar Limited, Interleaved 2 of 5, Inverse 1D, ISBT 128, Korean 3 of 5, Matrix 2 Of 5, MSI, UPC-A, UPC-E/ E1

Ángulo de escaneo:

Ancho: 47° (predeterminado) Medio: 35° Estrecho: 10°

Resolución óptica:

Ancho mínimo de elemento de 0,005 mm

Contraste de impresión:

Reflectancia de oscuridad absoluta/luz mínima del 25 % medida a 650 nm.

Distancia de lectura:

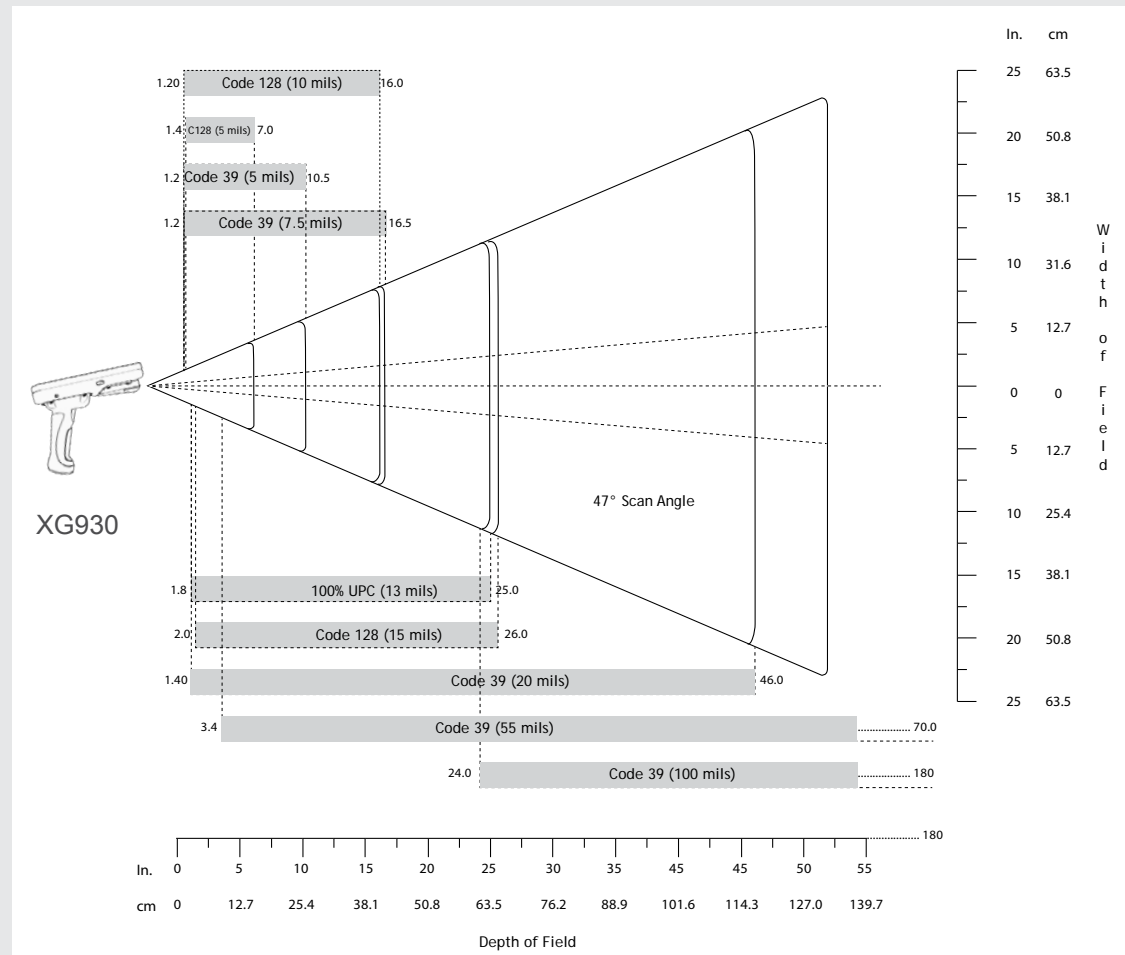

Códigos de barras 1D: de 3,05 cm a 457,2 cm

Depende del ancho y del tamaño del código de barras, de la simbología y del soporte de la etiqueta.

Rangos de decodificación:

	Minimo	Máximo
5 mils Code 39	1.2 in/3.0 cm	10.5 in/21.0 cm
5 mils Code 128	1.4 in/3.6 cm	7.0 in/26.7 cm
7.5 mils Code 39	1.2 in/3.0 cm	16.5 in/41.9 cm
10 mils Code 128	1.2 in/3.0 cm	16.0 in/40.6 cm
13 mils 100% UPC	1.8 in/4.6 cm	25.0 in/63.5 cm
15 mils Code 128	2.0 in/5.1 cm	26.0 in/66.0 cm
20 mils Code 39	1.4 in/3.6 cm	46.0 in/116.8 cm
55 mils Code 39	3.4 in/8.6 cm	70.0 in/177.8 cm
100 mils Code 39	24 in/61 cm	180.0 in/457.2 cm

Bluetooth (conexión inalámbrica)

Radio Bluetooth:	Bdelu 5eto6 biothts de clase 2, versión 2.1 + EDR (tasa mejorada de datos) con cifrado de datos
Rango de alcance:	Hasta 10 metros dependiendo del entorno de uso. El límite del rango de alcance depende en general del dispositivo al que esté conectado (teléfono, tableta o notebook)
Perfiles Bluetooth:	<i>Modo estándar - HID y Modo Aplicación - MFi-SPP* Algunos sistemas operativos o modelos de móvil/tableta podrían ser compatibles con un único tipo de perfil. *Por defecto, el escáner está configurado en Modo App - MFi- SPP.</i>

Los ordenadores Apple, Android y Windows con Bluetooth estándar HID son compatibles con todos los escáneres Socket Mobile. *Chromebook y Linux solo son compatibles con el modo HID.

Entorno de usuarios

Tolerancia a la luz ambiente:	De 4.800 a 86.000 lux. Desde luz artificial en interiores (fluorescente e incandescente) hasta luz natural en exteriores (luz solar directa)
Temperatura de funcionamiento:	De 0° to 45° C (32° to 113° F)
Temperatura de almacenamiento:	De -5° to 70° C (-22° to 158° F)
Temperatura de carga:	Las temperaturas superiores a 40 °C pueden conllevar problemas de carga.
Humedad relativa:	95% at 60° C (140° F) (sin condensación)
Estanqueidad:	IP65 (Ingress protection rating for dust and water) meets IEC sealing and EN60529 specification
Resistencia a caídas:	Estándar: 3,1 m a temperatura ambiente conforme a la norma MIL-STD-810G, 2,4 m sobre hormigón en la gama de temperaturas, según norma MIL-STD-810G Frigorífico: 2,1 m sobre hormigón en la gama de temperaturas, según norma MIL-STD-810G

Compatibilidad del sistema operativo

Apple iOS - Modo estándar (HID) y Modo Aplicación (MFi-SPP)

Compatible con dispositivos que soporten el protocolo de modo Básico (HID). Lenguajes de teclado soportados: ANSI, inglés británico, inglés, francés, alemán, italiano, japonés, polaco, español y sueco.

Garantía

Escáner:	Garantía limitada estándar de un año que cubre el escáner de códigos de barras
Accesorios:	90 días para las baterías y cable de carga.
Extensión de garantía	https://sckt.tech/socketcare-es

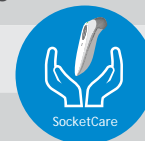

Certificaciones y normativas

Bluetooth SIG:	Declaration ID: D030529 QD ID: 82009
Seguridad:	EN 62368-1:2020 + A11:2020 IEC 62368-1:2018 UL 62368-1:2019 R10.21 CSA C22.2 NO. 62368-1:19
Medioambiente:	Medioambiental: RoHS EN 50581
Interferen:	FCC Part 15 Class C, RSS 210, iCES 003, C-Tick, CISPR 22, CE EN55022, EN55024, TELECOM: FCC ID: LUBMA41 IC ID: 2529A-MA41M9
Seguridad:	IEC 60825-1, EN 60825-1



Aplicaciones habituales

- Gestión de inventario en almacenes
- Gestión de la cadena de suministro
- Seguimiento de activos
- Envíos y recepciones
- Seguimiento de servicios comerciales móviles
- Industria y manufactura
- Construcción
- Industria automovil
- Sector del petróleo y del gas
- Industria aeroespacial
- Transporte y logística

socketmobile.com

Resto del mundo: +1 510 933 3000

Norteamérica: +1 800 552 3300

EMEA: +41 62 834 07 80

Francia: +33 970 462 241

sales@socketmobile.com

Región Asia-Pacífico +1 510 933 3122

Alemania: +41 62 834 07 80

Suiza: +41 62 834 07 80

Número gratuito para Suiza: +41 (800) 898003

sales-japan@socketmobile.com

Japón: +8190 9808 0518

Número gratuito para Japón: +81 (800) 9190303

Latinoamérica: +1-510-933-3153

RU, Irlanda y Sudáfrica: +44 (800) 0487363

©2024 Socket Mobile, Inc. Todos los derechos reservados. Socket®, el logotipo Socket Mobile, DuraScan®, DuraSled®, SocketScan®, XtremeScan™ y Battery Friendly® son marcas registradas de Socket Mobile, Inc. Microsoft® es una marca registrada de Microsoft Corporation, tanto en Estados Unidos como en otros países. Apple®, iPad®, iPad Mini®, iPhone®, iPod Touch® y Mac iOS® son marcas registradas de Apple, Inc., registradas tanto en Estados Unidos como en otros países. Bluetooth® y su logotipo son marcas registradas de Bluetooth SIG, Inc. y todo uso de ellas por parte de Socket Mobile, Inc. se hace bajo licencia. Otras marcas y nombres comerciales son propiedad de sus dueños respectivos.

Lecteur code-barres 1D laser



Le XtremeScanGrip XG930 est un dispositif portable modulaire durci qui combine une coque pour iPhone, un lecteur laser 1D et une poignée-pistolet pour vous offrir une solution de qualité professionnelle et capturer des données en mode viser-déclencher. Doté de capacités de lecture longue distance, il est particulièrement recommandé pour la capture de marquages au sol ou de racks en hauteur. Le lecteur est intégré dans une coque ultra-robuste conçue pour résister à une utilisation intensive dans un environnement industriel exigeant. La poignée-pistolet rend la prise en main plus confortable et plus pratique et vous permet de scanner en continu pendant de longues périodes. La coque de protection haute résistance est classée IP65 contre les poussières et les jets d'eau à basse pression. Elle comporte un chargeur sans fil intégré pour pouvoir charger l'iPhone sans le retirer de la coque.

Associé à un iPhone compatible, le lecteur laser XtremeScan Grip XG930 constitue une solution mobile polyvalente et puissante utilisable dans une grande variété d'applications industrielles. Le XG930 est équipé d'un laser de classe 2 qui scanne des codes-barres, même endommagés, à travers le plastique et le verre, dans des conditions de forte luminosité ou de faible éclairage, sur le côté ou à l'envers. Le XG930 scanne à une distance allant de 3 cm à 457 cm selon la symbologie, la largeur, la taille et le support du code-barre. Grâce à la robustesse de sa coque de qualité industrielle, il résiste à des chutes répétées sur surface en béton.

CARACTÉRISTIQUES

- **Compatible avec les iPhones 14 et 14 Pro, 13 et 13 Pro et 12 et 12 Pro.**
- **Numérisation** – lecteur code-barres 1D haute performance équipé d'un laser de classe 2. Idéal pour un usage modéré à intensif (capture plusieurs milliers de code-barres par jour). Scanne à une distance allant jusqu'à environ 457 cm (la distance de lecture dépend de la taille et de la qualité du code-barres).
- **Technologie Bluetooth sans fil** – connexion fiable par Bluetooth avec appareils iOS.
- **Battery Friendly®** – le lecteur dispose d'une batterie rechargeable, remplaçable sur le terrain et offrant une journée entière d'autonomie.
- **Indicateurs intuitifs** – des voyants LED indiquent le niveau de batterie, de charge et le statut de lecture.
- **Informations lecteur** – le lecteur émet des signaux sonores pour confirmer la capture de données.
- **Conception durcie** – étanchéité IP67 contre les poussières et les protections d'eau, excellente résistance aux chutes.
- **Poignet-pistolet** – une alternative pour un plus grand confort de lecture en mode viser-déclencher.
- **Protection renforcée** – le boîtier surmoulé en caoutchouc protège efficacement votre appareil Apple et le lecteur.
- **Chargement** – le boîtier permet le chargement simultané des deux appareils (iPhone et lecteur).
- **Accessoires** – dragonne et dock de charge bientôt disponibles (vendus séparément ou par pack).
- **Intégration d'applications** – le SDK de capture Socket Mobile permet une intégration facile à vos applications et l'optimisation de la productivité de votre entreprise grâce au transfert rapide, fiable et efficace de données par connexion Bluetooth sans fil. Le XG930 est livré prêt à fonctionner avec toute application intégrant le kit CaptureSDK.
- **Conçu et assemblé aux États-Unis.**
- **Garantie 1 an. Options d'extension de garantie disponibles.**

Caractéristiques physiques

Poids:

TBD

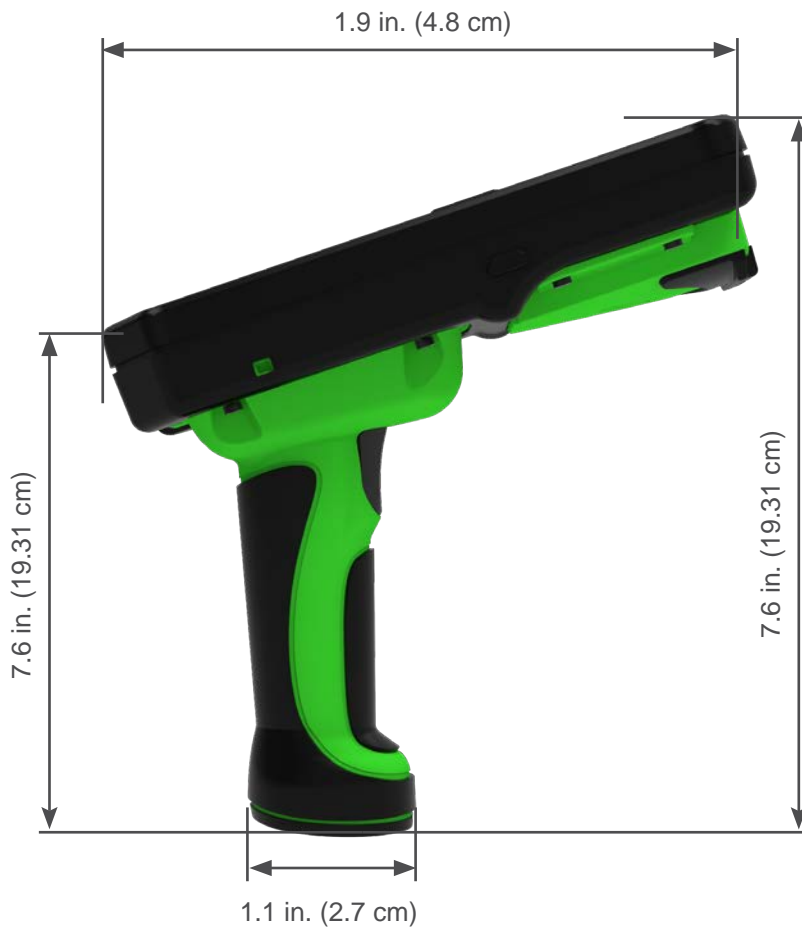

Contenu du pack

- (1) XG930 lecteur code-barres laser et batterie rechargeable (pré-installée)
- (1) Câble de chargement
- (1) Notice de démarrage



Téléchargez
gratuitement
l'application
Companion de
Socket Mobile!



Type de lecteur

Tecnología:	lecteur code-barres 1D avec laser de classe 2
Puissance du laser à 650 nm:	Mode lecture : 1,7 MW (puissance nominale) Mode visée : 0,67 MW

Batterie

Type de batterie	batterie rechargeable remplaçable - lithium ion polymère	
Durée de charge	8 heures	
Autonomie - par charge complète	Mode veille	25 heures
	Mode lecture	45 000 lectures en 4,5 heures (à raison de 2 lectures par seconde) 9 000 lectures en 10 heures (à raison de 1 lecture toutes les 4 secondes)
À noter	<i>la durée de vie de la batterie dépend de la température et de la lumière ambiantes ainsi que de l'âge de la batterie. Pour plus d'informations, cliquez ici</i>	
Nombre de batteries utilisées	1	
Poids de la batterie	12,5g	
Pourcentage de lithium	36%	
Capacité de la batterie	700 mAh	
Nombre de cellules par batterie	1	
Nombre de watt heure par batterie : 2,59	2,59	
Type de cellule (p.ex. AA)	propriétaire	
Composition chimique (p.ex. alcaline)	Lithium - polymère	
Quantité de lithium	14g	
Tension de la batterie	3,7v	
Numéro d'identification des marchandises dangereuses établi par les Nations Unies	UN3481, P.I. 967	
Indicateur de conformité ROHS	oui. Fourni avec le lecteur	
Batterie (uniquement) - pays d'origine :	China	
Code marchandise	8507.60.0000	

Performances de lecture

Symbologies par défaut

Bookland EAN, Code 39, Code 39 Full ASCII, Code 93, Code 128, EAN-8/JAN, Ean-13/JAN, GS1 DataBar, GS1 Databar Expanded, GS1 DataBar Limited, GS1-128, Interleaved 2 of 5, ISBT 128, UPC A, UPC E

Symbologies prises en charge

Bookland EAN, Chinese 2 of 5, Codabar, Code 11, Code 39, Code 93, Code 128, Discrete 2 of 5, EAN-8, EAN 13, GS1-128, GS1 Databar, GS1 Databar Expanded, GS1 Databar Limited, Interleaved 2 of 5, Inverse 1D, ISBT 128, Korean 3 of 5, Matrix 2 Of 5, MSI, UPC-A, UPC-E/ E1

Angle de lecture

large : 47° (par défaut). Moyen : 35°. Étroit : 10°

Résolution du capteur

largeur minimale d'élément 0,127 mm

Contraste d'impression minimum

25 % différentiel de réflectance absolu noir/blanc mesuré à 650 nm.

Distance de lecture

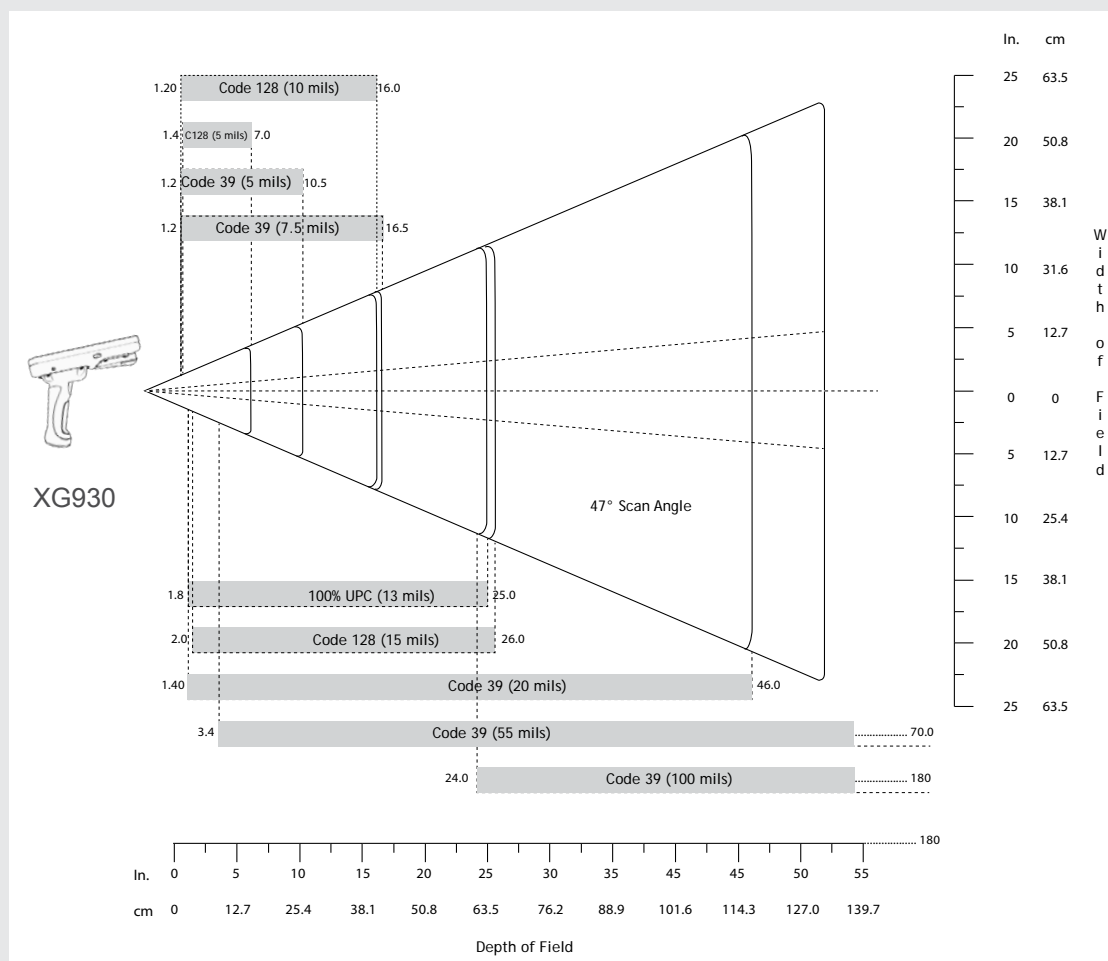

Code-barres 1D : 3,05 cm à 457,2 cm

Dépend de la largeur et de la taille du code-barres, de la symbologie et au type de support.

Plages de décodage

	Distance minimum	Distance maximum
5 mils Code 39	1.2 in/3.0 cm	10.5 in/21.0 cm
5 mils Code 128	1.4 in/3.6 cm	7.0 in/26.7 cm
7.5 mils Code 39	1.2 in/3.0 cm	16.5 in/41.9 cm
10 mils Code 128	1.2 in/3.0 cm	16.0 in/40.6 cm
13 mils 100% UPC	1.8 in/4.6 cm	25.0 in/63.5 cm
15 mils Code 128	2.0 in/5.1 cm	26.0 in/66.0 cm
20 mils Code 39	1.4 in/3.6 cm	46.0 in/116.8 cm
55 mils Code 39	3.4 in/8.6 cm	70.0 in/177.8 cm
100 mils Code 39	24 in/61 cm	180.0 in/457.2 cm

Bluetooth (connexion sans fil)

Bluetooth Radio:	Bluetooth classe 2, version 2.1 + EDR (Enhanced Data Rates) cryptage 56 bits
Portée Bluetooth	jusqu'à 10 m selon l'environnement d'utilisation, la limite de portée dépend généralement du périphérique connecté (smartphone, tablette ou ordinateur portable).
Profils Bluetooth	<i>Mode standard - HID*, mode application - MFi-SPP*. Certains systèmes d'exploitation ou modèles de smartphones et de tablettes ne prennent en charge qu'un seul profil.</i> *Le lecteur est configuré par défaut en mode application MFi-SPP.

Apple, Android et Windows PC avec Bluetooth en mode standard HID sont compatibles avec tous les lecteurs Socket Mobile.

*Prise en charge de Chromebook et Linux en mode HID uniquement

Environnement utilisateur

Lumière ambiante	de 4 800 à 86 000 lux. De la lumière artificielle (fluorescent & incandescent) à la lumière naturelle (lumière solaire directe).
Température de fonctionnement	0° to 45° C (32° to 113° F)
Température de stockage	-5° to 70° C (-22° to 158° F)
Température de chargement	les températures supérieures à 40° C peuvent entraîner des problèmes de chargement.
Humidité relative	95 % à 60° C (sans condensation)
Étanchéité	IP65 (indice de protection Ingress contre la poussière et les projections d'eau) EN60529.
Résistance aux chutes	Standard: 3,1m à température ambiante conforme à la norme MIL-STD-810G, 2,4 m suivant les conditions ambiantes sur surface en béton MIL-STD-810G. Frigos: 2,1 m suivant les conditions ambiantes sur surface en béton MIL-STD-810G.

Systèmes d'exploitation

Apple iOS: Mode standard (HID) et mode application (MFi-SPP)

Compatible avec les appareils prenant en charge le protocole standard HID. Langages clavier pris en charge - ANSI, anglais Royaume-Uni, anglais, français, allemand, italien, japonais, polonais, espagnol et suédois.

Garantie

Lecteur	garantie standard limitée à 1 an pour les lecteurs code-barres
Accessoires	90 jours pour les batteries et le câble d'alimentation
Extension de garantie (vendue séparément)	https://sckt.tech/socketcare-fr



Réglementation & certification

Bluetooth SIG:	Declaration ID: D030529 QD ID: 82009
Sécurité électrique	EN 62368-1:2020 + A11:2020 IEC 62368-1:2018 UL 62368-1:2019 R10.21 CSA C22.2 NO. 62368-1:19
Normes environnementales	RoHS EN 50581
EMI / RFI	FCC Part 15 Class C, RSS 210, iCES 003, C-Tick, CISPR 22, CE EN55022, EN55024, TELECOM: FCC ID: LUBMA41 IC ID: 2529A-MA41M9
Sécurité laser	IEC 60825-1, EN 60825-1



Applications

Gestion d'entrepôts

Gestion de la chaîne d'approvisionnement

Suivi d'actifs

Réception & expédition

Suivi mobile pour services commerciaux

Secteur industriel & manufacturier

Secteur du BTP

Automobile

Secteur du pétrole et du gaz

Aérospatiale

Transport & logistique

socketmobile.com

International +1 510 933 3000

Amérique du Nord +1 800 552 3300

EMEA: +41 62 834 07 80

France: +33 970 462 241

sales@socketmobile.com

Asie Pacifique +1 510 933 3122

Allemagne: +41 62 834 07 80

Suisse: +41 62 834 07 80

Suisse numéro gratuit +41 (800) 898003

sales-japan@socketmobile.com

Japon: +8190 9808 0518

Japon numéro gratuit +81 (800) 9190303

Amérique latine +1-510-933-3153

Royaume-Uni/Irlande/Afrique du Sud +44 (800) 0487363

©2024 Socket Mobile, Inc. Tous droits réservés. Socket®, le logo Socket Mobile, SocketScan®, DuraScan®, DuraSled®, SocketCam®, XtremeScan™ et Battery Friendly® sont des marques commerciales ou des marques déposées par Socket Mobile, Inc. Microsoft® est une marque déposée de Microsoft Corporation aux États-Unis et dans d'autres pays. Apple®, iPad®, iPad Mini®, iPhone®, iPod Touch®, et Mac iOS® sont des marques commerciales d'Apple Inc. déposées aux États-Unis et dans d'autres pays. La marque et les logos Bluetooth® Technology sont des marques commerciales déposées appartenant à Bluetooth SIG, Inc. et utilisées sous licence par Socket Mobile, Inc. Toutes autres marques et noms commerciaux appartiennent à leurs propriétaires respectifs.

1D レーザーバーコードスキャナー



XtremeScan グリップ型 XG930 レーザー 1D バーコード スキャナは、iPhone ケース、スキャナ、ピストル グリップ ハンドルを組み合わせたモジュール式の頑丈なハンドヘルド モバイル デバイスです。長距離スキャン機能を備えているため、フロアラベルのバーコードや高い棚のラックラベルをスキャンするアプリケーションに最適です。スキャナーと頑丈なケースを一体にしたことで、要求の厳しい産業環境に耐えられ、ピストル グリップ ハンドルにより、長時間のシフト中の継続的なスキャンにさらなる快適さと利便性を提供します。XtremeScan ケースは IP65 密閉ハウジングとなっており、低圧水の噴流から保護します。ワイヤレス充電器が内蔵されているので、ケースから取り外さずにiPhoneを充電できます。

XG930 にはクラス 2 レーザーが搭載されており、明るいまたは暗い照明条件下で、プラスチックまたはガラスを通して、不完全なバーコードを横向き、逆さま、またはまっすぐにスキャンします。バーコード シンボル、幅、サイズ、ラベル メディアに応じて、XG930 は 3.0 cm から 457.2 cm までスキャンできます。工業グレードの頑丈なハウジングは、コンクリート上への複数回の落下にも耐えることができます。

特徴

- iPhone 14 & 14 Pro, iPhone 13 & 13 Pro, 並びにiPhone 12 & 12 Proが使えます。
- **スキャンング** – 高性能 1D クラス 2 レーザーは、例えば(1 日に数千のバーコードをスキャンするなどの業務 に最適で、レーザー スキャナーで最大457.2 cm 離れた場所からスキャンできます。(スキャン距離はバーコードのサイズと品質によって異なります)
- **Bluetooth** – iOSデバイスとはBluetoothで接続。
- **長時間動作で交換可能な電池** – Bフルシフトで使える長時間電池で、電池はフィールドで交換可能。
- **表示器** – スキャンング状態と電池充電状態を表示する直観的で見やすいLED。
- **スキャナーフィードバック** – Sスキャンが成功すると可聴音が鳴ります。
- **堅牢設計** – IP65準拠の防塵防滴構造で複数の落下に耐えられます。
- **ピストルグリップハンドル** – スキャンング作業が快適。
- **保護** – O堅牢なラバーケースでiPhoneとスキャナーを衝撃から保護します。
- **充電** – iPhoneとスキャナーを同時充電。
- **アクセサリ** – Hハンドストラップと充電ドック(近日発売)。
- **アプリの組み込み** – Socket Mobile の Capture SDK を使用すると、アプリケーションに簡単に統合でき、Bluetooth ワイヤレス テクノロジーを介した高速、効率的、信頼性の高いデータ転送によりビジネスの生産性が向上します。XG930 は、すでに CaptureSDK が統合されているアプリですぐに使用できます。
- **1年保証 (保証期間延長サービスあり)。**

物理的仕様

重量

TBD



同梱物

- (1) XG930レーザーバーコードスキャナー&充電池(内蔵)
- (1) 充電ケーブル
- (1) スタートガイド



Socket Mobile
Companion App
ダウンロード!



スキャナータイプ

技術:	1D Class 2レーザーバーコードスキャナー
レーザー出力@650 nm :	スキャンモード: 1.7 mW (公称ピーク出力) エイミングモード: 0.67 mW

電池

タイプ:	Replaceable Lithium Ion Polymer- rechargeable battery	
充電時間:	8 hours	
満充電からの電池動作時間	スタンバイ時間:ア クティブスキャン時 間 -	25時間 4.5時間以内に45,000スキャン (毎秒2スキャン) 10時間以内に9,000 スキャン (4秒ごとに1スキャン)
備考:	電池動作時間は周囲温度、周囲光、電池の使用時間に依存します。詳細は こちら .	
電池数:	1	
重量:	12,5g	
リチウムの比率:	36%	
電池容量:	700 mAh	
電池当たりのセル数:	1	
ワット時間:	2,59	
セルのタイプ:	propriétaire	
化学混合物	Lithium - polymère	
リチウムの量:	14g	
電圧:	3,7v	
Hazmat UN Number:	UN3481, P.I. 967	
ROHS表記:	oui. Fourni avec le lecteur	
電池原産国:	China	
Commodity Code:	8507.60.0000	

Performances de lecture

デフォルトバー コードシンボル:

Bookland EAN, Code 39, Code 39 Full ASCII, Code 93, Code 128, EAN-8/JAN, Ean-13/JAN, GS1 DataBar, GS1 Databar Expanded, GS1 DataBar Limited, GS1-128, Interleaved 2 of 5, ISBT 128, UPC A, UPC E

サポートするバーコードシンボル:

Bookland EAN, Chinese 2 of 5, Codabar, Code 11, Code 39, Code 93, Code 128, Discrete 2 of 5, EAN-8, EAN 13, GS1-128, GS1 Databar, GS1 Databar Expanded, GS1 Databar Limited, Interleaved 2 of 5, Inverse 1D, ISBT 128, Korean 3 of 5, Matrix 2 Of 5, MSI, UPC-A, UPC-E/E1

スキャン角度:

Wide: 47° (デフォルト) Medium: 35° Narrow: 10°

光学解像度:

0.005 in. 最小エレメント幅

印字コントラスト:

Minimum 25% absolute dark/light Reflectance measured at 650 nm

読み取り距離

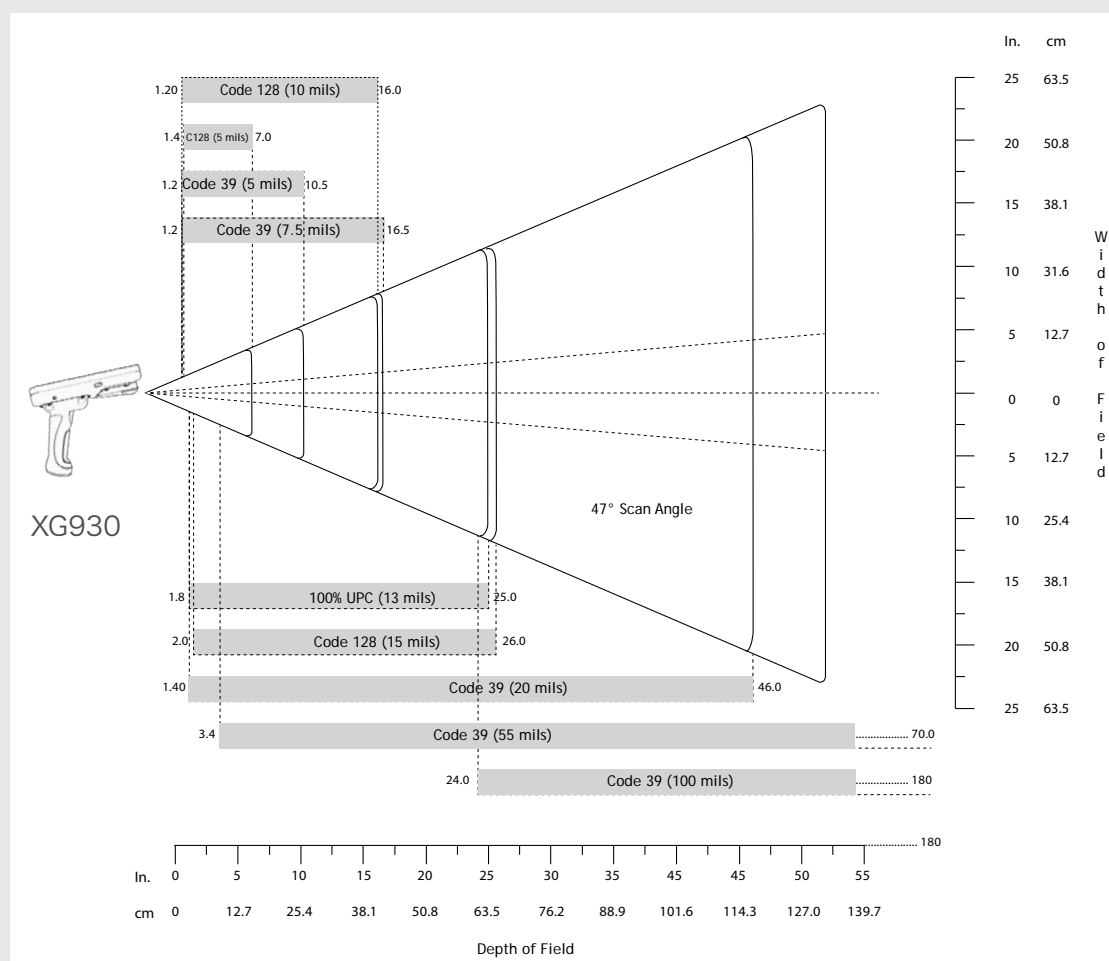

1D codes 3.05 to 457.2 cm
幅やサイズ、シンボル、ラベル媒体に依存

デコード範囲:

	Distance minimum	Distance maximum
5 mils Code 39	1.2 in/3.0 cm	10.5 in/21.0 cm
5 mils Code 128	1.4 in/3.6 cm	7.0 in/26.7 cm
7.5 mils Code 39	1.2 in/3.0 cm	16.5 in/41.9 cm
10 mils Code 128	1.2 in/3.0 cm	16.0 in/40.6 cm
13 mils 100% UPC	1.8 in/4.6 cm	25.0 in/63.5 cm
15 mils Code 128	2.0 in/5.1 cm	26.0 in/66.0 cm
20 mils Code 39	1.4 in/3.6 cm	46.0 in/116.8 cm
55 mils Code 39	3.4 in/8.6 cm	70.0 in/177.8 cm
100 mils Code 39	24 in/61 cm	180.0 in/457.2 cm

Bluetooth (connexion sans fil)

Bluetooth無線	Bluetooth classe 2, version 2.1 + EDR (Enhanced Data Rates) cryptage 56 bits
Bluetooth 距離	10 metersまで。環境ホストデバイスに依存
Bluetoothプロファイル:	Basic Mode - Human Interface Device (HID)並びにApp Mode - MFi-SPP*.. *デフォルトでは、スキャナーはApp Mode - MFi-SPPに設定されています

Bluetooth Classic HID を搭載したApple, Android並びにWindows PCはSocket Mobileの全てのスキャナーと互換です。
*ChromebookやLinuxはHID modeのみサポート。

使用環境

周囲光:	From 4,800 to 86,000 lux From artificial indoor (fluorecent and incandescent) to natural outdoor lighting (direct sunlight)
動作温度 Temperature:	0° to 45° C (32° to 113° F)
保存温度Temperature	-5° to 70° C (-22° to 158° F)
充電温度:	40° C以上の周囲温度で充電しないでください。
相対湿度:	95% at 60° C (non-condensing)
シーリング:	IP65 (防塵防滴)、IECシーリングとEN60529仕様
落下仕様:	標準: 室温で3.1mからの落下: MIL-STD-810G, 全温度範囲でコンクリートへ2.4mからの落下: MIL-STD-810G. 全温度範囲コンクリートへ2.1mからの落下: MIL-STD-810G. フリーザ:

OS

Apple iOS - Basic Mode (HID)とApp Mode (MFi-SPP)

HIDサポートのデバイスと互換. サポートキーボード言語 - ANSI, English UK, English, French, German, Italian, Japanese, Polish, Spanish and Swedish

保証

スキャナー本体:	1年
アクセサリ:	90日
保証期間延長プログラム(別売)	https://sckt.tech/socketcare-jp



認定と規格

Bluetooth SIG:	Declaration ID: D030529 QD ID: 82009
Sécurité électrique	EN 62368-1:2020 + A11:2020 IEC 62368-1:2018 UL 62368-1:2019 R10.21 CSA C22.2 NO. 62368-1:19
Normes environnementales	RoHS EN 50581
EMI / RFI	FCC Part 15 Class C, RSS 210, iCES 003, C-Tick, CISPR 22, CE EN55022, EN55024, TELEC: FCC ID: LUBMA41 IC ID: 2529A-MA41M9
Sécurité laser	IEC 60825-1, EN 60825-1



主な用途

在庫管理

サプライチェーン管理

資産管理

入出庫管理

コマースサービスにおけるモバイルトラッキング

製造業

建築業

自動車

石油ガス

航空

輸送

socketmobile.com

Worldwide: +1 510 933 3000

North America: +1 800 552 3300

EMEA: +41 62 834 07 80

France: +33 970 462 241

sales@socketmobile.com

Asia Pacific: +1 510 933 3122

Germany: +41 62 834 07 80

Switzerland: +41 62 834 07 80

Switzerland Toll-Free: +41 (800) 898003

sales-japan@socketmobile.com

Japan: +8190 9808 0518

Japan Toll-Free: +81 (800) 9190303

Latin America: +1-510-933-3153

UK/Ireland/South Africa: +44 (800) 0487363

©2024 Socket Mobile, Inc. All rights reserved. Socket®, the Socket Mobile logo, DuraScan®, SocketScan®, Battery Friendly® are registered trademarks or trademarks of Socket Mobile, Inc. Microsoft® is a registered trademark of Microsoft Corporation in the United States and other countries. Apple®, iPad®, iPad Mini®, iPhone®, iPod Touch®, and Mac iOS® are registered trademarks of Apple, Inc., registered in the U.S. and other countries. The Bluetooth® Technology word mark and logos are registered trademarks owned by the Bluetooth SIG, Inc. and any use of such marks by Socket Mobile, Inc. is under license. Other trademarks and trade names are those of their respective owners.